

## Micro thin film type sensor probe

# F $\mu$ Thermistor

The F micro thin film thermistor sensor probe has been developed applying SEMITEC's proprietary thin film thermistor technology, specifically with medical purposes in mind. It is highly suited for catheter applications with its high volume production capability, robustness, reliability, accuracy and faster response than existing thermistors.

### Product number explanation

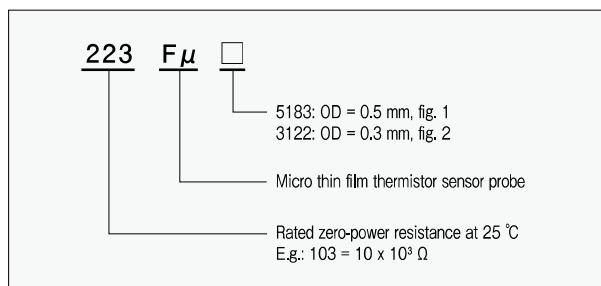

### Applications

Medical catheters  
Guide wires  
Testing equipment  
Handheld medical devices  
Body temperature monitoring  
Other applications that require very small probes

### Resistance / temperature characteristics

Temperature (°C)	223F $\mu$ <sup>5</sup>
-10	100.3
0	62.92
10	40.56
20	26.82
30	18.16
40	12.58
50	8.892
60	6.407
70	4.700

<sup>5</sup>: Resistance values for the thermistor chip without lead wires

### Specifications

Product number	R <sub>37</sub> <sup>1</sup>	R <sub>37</sub> tolerance	B value <sup>2</sup>	Dissipation factor (mW / °C)	Thermal time constant (ms) <sup>3</sup>	Rated power at 25°C (mW)	Operating temperature range (°C)
223F $\mu$ 5183	14.015 k $\Omega$	$\pm 0.5\%$ <sup>4</sup>	3454 K $\pm 1\%$	approx. 0.35	approx. 52	1.75	- 10 to 70
223F $\mu$ 3122	14.015 k $\Omega$	$\pm 3\%$ <sup>4</sup>	3454 K $\pm 1\%$	approx. 0.22	approx. 20	1.1	- 10 to 70

<sup>1</sup>: Rated zero-power resistance at 37 °C of the thermistor chip without lead wires

<sup>2</sup>: B value calculated from rated zero-power resistance at 0 °C and 50 °C without lead wires

<sup>3</sup>: Time required to reach 63.2% of temperature difference. Measured with sensor suspended in still water.

<sup>4</sup>: If your application requires other tolerance values please contact SEMITEC sales staff.

### Reliability data

Item	Test conditions	Criteria
Free fall	Three times natural fall to a maple board from 1 m height.	$\Delta R, \Delta B \pm 0.5\%$
Dry heat	1000 hours at 70 °C	
Damp heat	1000 hours at 70 °C and 90% to 95% humidity	
Temperature cycle (thermal shock)	Seven cycles as below: 1. - 20 °C for 12 hours 2. Room temperature for 1 minute 3. 55 °C for 12 hours 4. Room temperature for 1 minute	

### Caution

The F micro thermistor sensor probe is manufactured using a semiconductor process. Due to its microstructure the sensor is sensitive to electrostatic discharge (ESD) in just the same way as common integrated circuits are.

In order to prevent damage to or failure of the sensor SEMITEC recommends to take appropriate precautions against ESD when handling it.

Failure to protect the sensor against ESD may also cause damage to the equipment installed with the sensor, because electrostatic discharge can cause small parametric changes, which means that the sensor may not meet its published specification.

### Dimensions

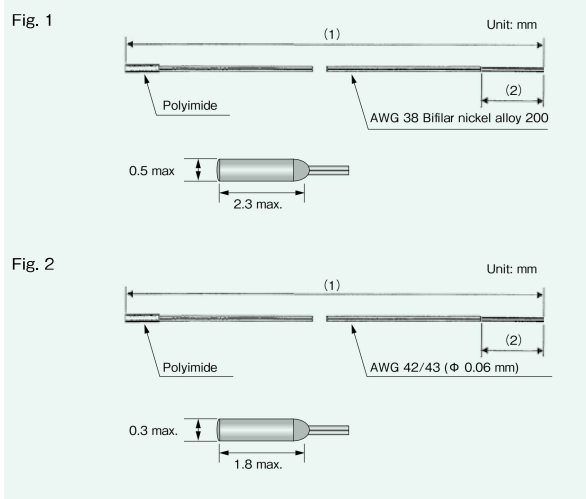

(1) Lead wire length customized according to customer requirements (max. 200 cm).  
(2) Bare lead wire length customized according to customer requirements.

Please contact SEMITEC sales staff for products without resin coating on the sensor head for even smaller diameter.

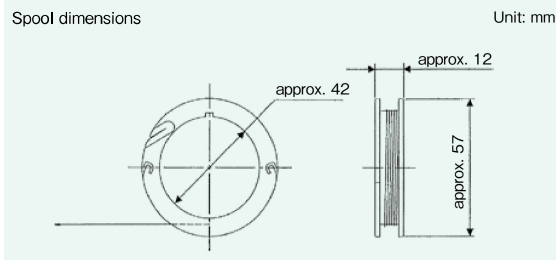

### Connection method

The lead wire can be soldered to larger wires by winding it around the larger wire and then soldering.

Please contact SEMITEC sales staff for customized bare lead wire lengths according to your application's requirements.

## ■ Non-contact (IR) temperature sensor



# NC Sensor

The NC Sensor uses SEMITEC's extremely small FT thermistors as temperature sensing elements to create a robust IR sensor that can be used in many different locations and formerly impossible environments.

### ■ Product number explanation

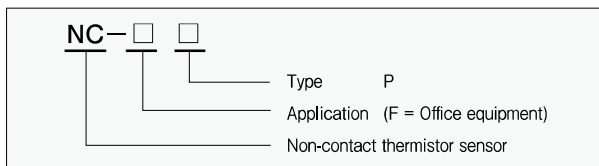

### ■ Applications

- Office automation fuser roller applications such as LBP, PPC etc.
- Rotating parts in automotive applications
- Rotating motor parts
- Temperature measurement in high pressure environments
- Temperature measurement of drugs and chemicals

### ■ Specifications

Parameter	Value	Conditions
Measurement center	180 °C ± 3 °C	Blackbody temp.: 180 °C; sensor body temp.: 100 °C Roller diameter: 40 mm; distance: 5 mm
Responsivity	1.3 s ± 0.5 s	Time required to reach 63.2% of temperature difference between blackbody and sensor body.
Operating temp. range	- 10 °C to 150 °C	—
Measuring temp. range	- 20 °C to 260 °C	—
Thermistor resistance value	7 kΩ ± 3%	Rated zero-power resistance at 180 °C
Thermistor B value	3370 K ± 1%	B value determined by rated zero-power resistance at 25 °C and 85 °C

### ■ Reliability data

Item	Test conditions	Criteria
Dry heat	1000 hours at 150 °C	Measurement center within ± 5 °C of initial value
Dry heat under electrical load	1000 hours at 150 °C, 5 V load	
Temperature cycle (thermal shock)	5 cycles as below: 1. - 20 °C for 30 minutes 2. Room temperature for 5 minutes 3. 150 °C for 30 minutes 4. Room temperature for 5 minutes	Over 100 MΩ
Insulation resistance	500 V DC (between aluminium case and connections)	
Voltage proof	500 V AC for one minute (between aluminium case and connections)	Less than 1 mA

### ■ Data table (approx.)

Compensation temperature (°C)	Compensation output (Vc)	Roller temperature (°C)																		
		0	20	40	60	80	100	120	140	160	180	200	220	240	260					
0	4.838	4.838	4.836	4.834	4.831	4.827	4.823	4.818	4.812	4.805	4.797	4.787	4.775	4.760	4.741					
10	4.758		4.757	4.754	4.750	4.745	4.740	4.733	4.726	4.716	4.706	4.692	4.677	4.658	4.634					
20	4.651		4.651	4.646	4.641	4.635	4.628	4.620	4.610	4.599	4.585	4.569	4.549	4.525	4.496					
30	4.509			4.506	4.500	4.493	4.484	4.474	4.462	4.448	4.431	4.411	4.388	4.359	4.325					
40	4.331			4.331	4.323	4.315	4.304	4.292	4.278	4.262	4.242	4.219	4.191	4.158	4.119					
50	4.115				4.110	4.100	4.088	4.075	4.059	4.040	4.018	3.992	3.961	3.925	3.881					
60	3.863					3.863	3.852	3.839	3.824	3.806	3.786	3.762	3.734	3.701	3.662	3.615				
70	3.581						3.574	3.561	3.545	3.527	3.505	3.481	3.452	3.418	3.377	3.329				
80	3.277							3.277	3.263	3.247	3.228	3.207	3.183	3.154	3.120	3.079	3.032			
90	2.962								2.955	2.939	2.922	2.901	2.877	2.849	2.816	2.778	2.732			
100	2.648									2.648	2.633	2.616	2.597	2.575	2.549	2.518	2.482	2.440		
110	2.344										2.337	2.322	2.304	2.284	2.260	2.233	2.200	2.162		
120	2.058											2.058	2.045	2.029	2.011	1.991	1.966	1.938	1.904	
130	1.796												1.790	1.777	1.761	1.743	1.723	1.698	1.669	
140	1.560													1.560	1.549	1.536	1.521	1.503	1.482	1.458
150	1.352														1.347	1.336	1.323	1.309	1.291	1.271

Measurement conditions

Applied voltage (E): 5 V Resistor resistance (R1, R2): 33 kΩ Blackbody roller: Φ 40 mm Installation distance: 5 mm

Unit: V

### ■ Dimensions

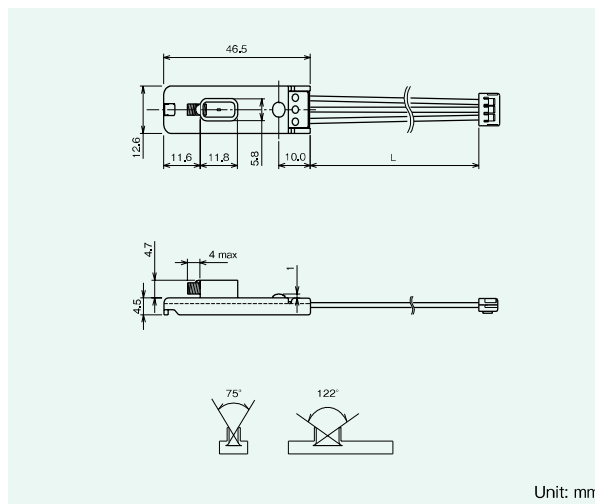

### ■ Temperature conversion circuit example

